

SMI 230V AC

Specification, printing errors and details are subject to change without notification.

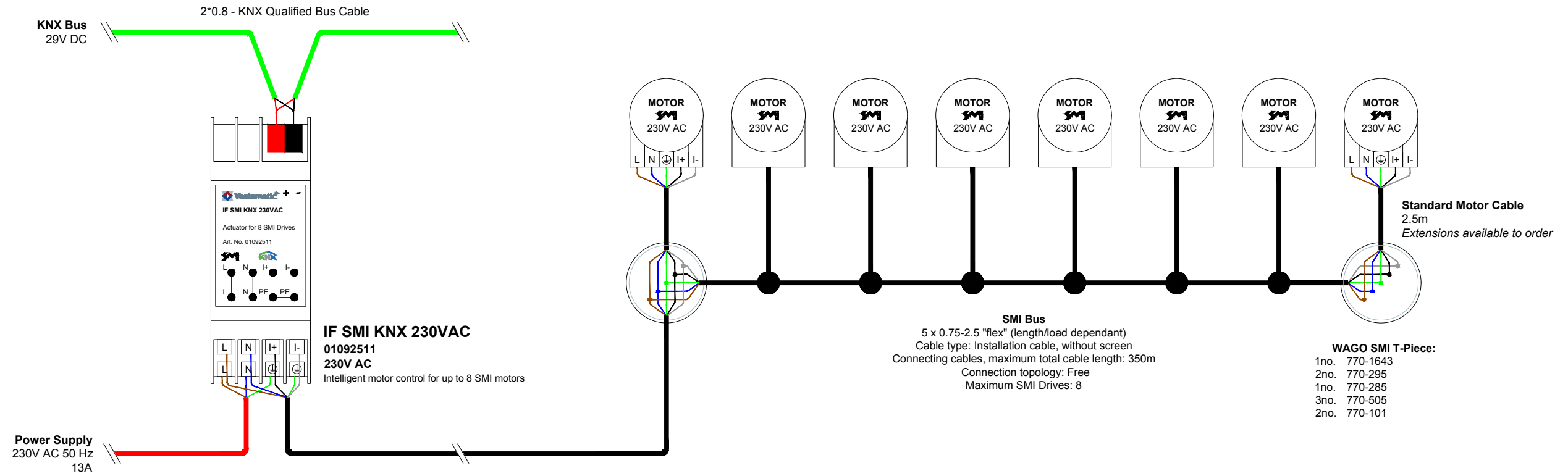

SMI 24V DC

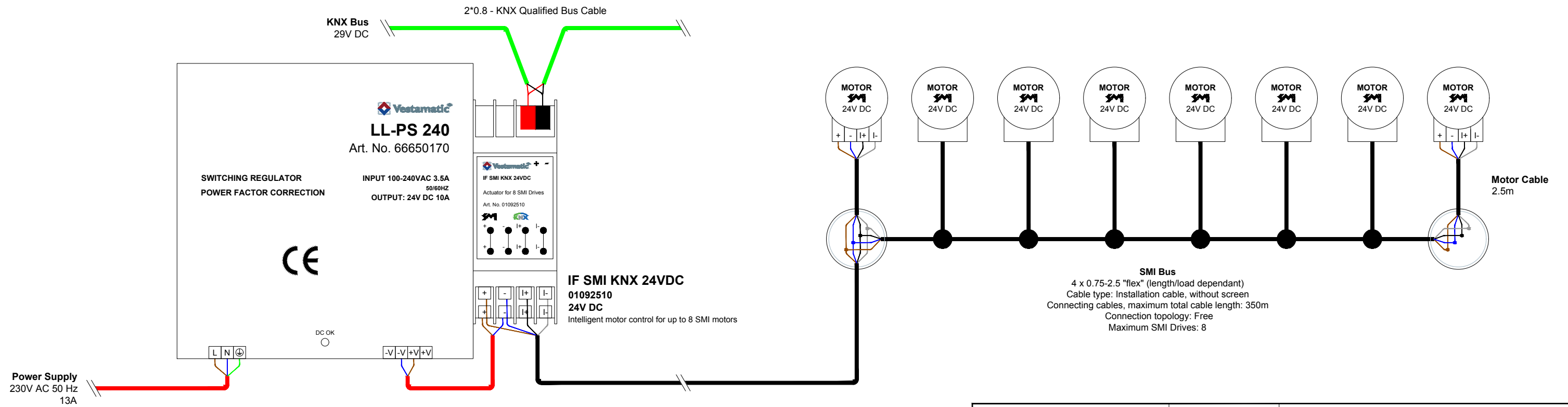

Project Name: Vestamatic® Solution Guide 12	Drawing no.: SG13.SMI.KNX Rev: A	Drawing produced by: Daren Whistler Business Development Director UK & Ireland +44 (0)7917 365 552 daren.whistler@vestamatic.com
Dwg Title: SMI Motor Control KNX	Date: 26.05.18 Print Size: A3	 Dohrweg 27 41066 Mönchengladbach Germany www.vestamatic.com